

**Aeroquip®**  
Low Profile Self Sealing Couplings

Series 2000  
Series 2001

**Request Quote**



**HERBER**

[www.herberaircraft.com](http://www.herberaircraft.com)



*Powering Business Worldwide*

# Low Profile Self Sealing Couplings

## 2000 and 2001 Opposed Poppet Series

Qualified to MIL-C-7413B Type I, Class A and Type II, Class B

Eaton's Aeroquip Low Profile 2000 and 2001 Series Couplings are used wherever a fast, safe connection is required for fuel and lube oil systems. These couplings provide lighter weight and smaller envelope size when compared to couplings which meet MIL-C-7413A.

The 2000 Series coupling easily connects by rotating the union mechanism and engaging the ratchet teeth. This positive thread action

permits connection against line pressures to 60 psi (413.68 kPa). The opposed poppet valve design provides a smooth, straight through fluid flow and low pressure drop.

The 2001 Series coupling shares the same design characteristics as the 2000 Series coupling. The difference is the connecting mechanism. The 2001 Series is quickly connected and disconnected with a simple push-pull motion. Both low-profile coupling series feature electrical continuity.

## 2000 Series Couplings

Low profile ratchet lock couplings for fuel and oil applications are available with various end fitting combinations. Select the base part number for coupling halves from the table on page 3. Complete the part number by adding the letter code (for size) to the base number, e.g. AE80827E.

Couplings for other fluids and end fitting styles are available. Dust caps and plugs are available for all sizes. Contact Eaton for further information or to order.



Series 2000 Coupling Assembly

## Design Data

<b>Application:</b>	MIL-C-7413B Type I, Class A - Fuel MIL-C-7413B Type II, Class B - Lube Oil
<b>Temperature Range:</b>	-65°F to +160°F (-54°C to +71°C) — Type I, Class A -65°F to +350°F (-54°C to +177°C) — Type II, Class B
<b>Electrical Resistance:</b>	1 ohm - connected
<b>Pressure:</b>	Operating — 600 psig (41,38 Bar) Proof — 900 psig (62,06 Bar) Minimum Burst — 1800 psig (123,13 Bar)
<b>Basic Material:</b>	Aluminum
<b>Packings:</b>	Fluorocarbon and fluorosilicone

## Dimensional Data

See chart on page 3.

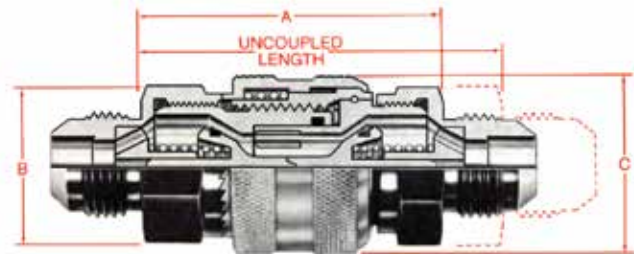

Coupling Assembly

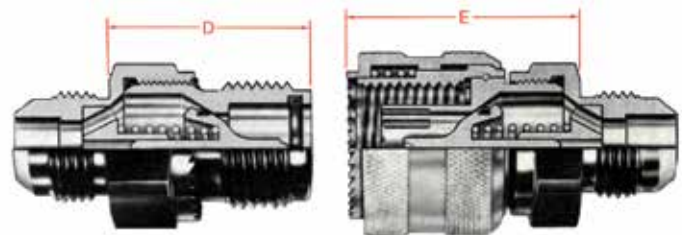

Coupling Half Bulkhead Mounting

Coupling Half Hose Attaching

Styles and Part Numbers

Coupling Half	Style I AS4395 AS4395		Style II AS4396 AS4395		Style III AS4375 AS4375		Style IV AS4377 AS4375		
	Application		Application		Application		Application		
Application	Fuel	Lube Oil	Fuel	Lube Oil	Fuel	Lube Oil	Fuel	Lube Oil	
Specification	MIL-C-7413B Type I, Class A	MIL-C-7413B Type II, Class B	MIL-C-7413B Type I, Class A	MIL-C-7413B Type II, Class B	MIL-C-7413B Type I, Class A	MIL-C-7413B Type II, Class B	MIL-C-7413B Type I, Class A	MIL-C-7413B Type II, Class B	
Part Number	Coupling Half P/N Bulkhead Mounting	AE80825	AE80831	AE80824	AE80830	AE80828	AE80834	AE80827	AE80833
	Coupling Half P/N Hose Attaching	AE80826	AE80832	AE80826	AE80832	AE80829	AE80835	AE80829	AE80835

Select the base part number for coupling halves from the table above. Complete the part number by adding the letter code (for size) to the base number (e.g. AE80827E).

To determine overall length, add the end fitting dimension for each end (dimension F, G, H or I from below) to the base assembly length (A or "uncoupled" dimension) for the desired coupling style. For coupling half length, add end fitting dimensions to the basic length (dimension D or E).

End Fitting Dimensions

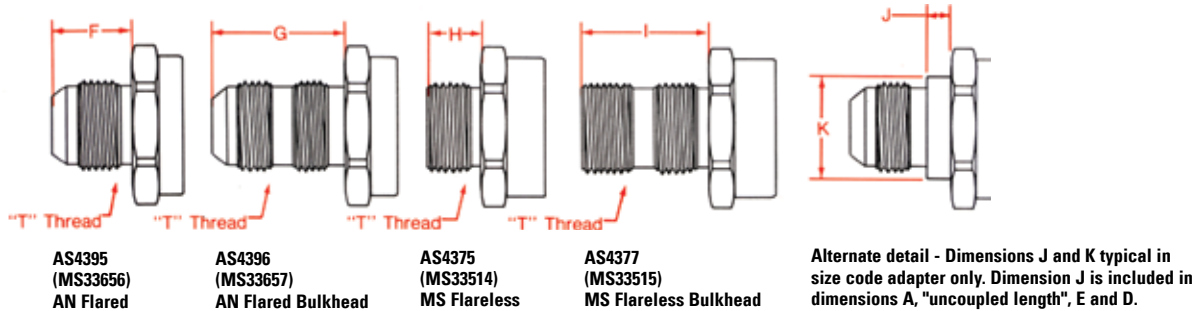

Dimensions shown in inches (mm). Weights shown in pounds (kg).

Letter Code	E	G	H	J	K	M	N	P	
Tube Size	1/4	3/8	1/2	5/8	3/4	1	1-1/4	1-1/2	
Dimensions	A	1.60 (40,640)	1.80 (45,720)	1.91 (48,514)	2.275 (57,785)	2.39 (60,706)	2.569 (65,253)	4.070 (103,378)	3.388 (86,055)
	Uncoupled Length	2.168 (55,067)	2.48 (62,992)	2.637 (66,980)	3.242 (82,347)	3.353 (85,166)	3.856 (97,942)	5.73 (145,542)	5.04 (128,016)
	B	.820 (20,828)	.970 (24,638)	1.170 (29,718)	1.450 (36,830)	1.520 (38,608)	1.790 (45,466)	2.400 (60,960)	2.400 (60,960)
	C	.920 (23,368)	1.000 (25,400)	1.190 (30,226)	1.480 (37,592)	1.640 (41,656)	1.910 (48,514)	2.400 (60,960)	2.400 (60,960)
	D (Max.)	.985 (25,019)	1.135 (28,829)	1.163 (29,540)	1.468 (37,287)	1.561 (39,649)	1.890 (48,006)	2.663 (67,640)	2.208 (56,083)
Weight	Style I	.082 (0,037)	.114 (0,052)	.173 (0,079)	.312 (0,142)	.414 (0,188)	.618 (0,281)	1.195 (0,543)	1.127 (0,512)
	Style II	.087 (0,039)	.122 (0,055)	.190 (0,086)	.336 (0,153)	.450 (0,204)	.664 (0,302)	1.234 (0,560)	1.181 (0,536)
	Style III	.080 (0,036)	.110 (0,050)	.169 (0,077)	.298 (0,135)	.394 (0,179)	.580 (0,263)	1.146 (0,520)	1.034 (0,469)
	Style IV	.085 (0,037)	.118 (0,054)	.183 (0,083)	.318 (0,144)	.430 (0,195)	.626 (0,284)	1.200 (0,545)	1.120 (0,509)
Dimensions	E (Max.)	1.229 (31,217)	1.397 (35,484)	1.518 (38,557)	1.817 (46,152)	1.835 (46,609)	2.013 (51,130)	3.064 (77,826)	2.609 (66,269)
	Hex 1	.750 (19,050)	.875 (22,225)	1.062 (26,975)	1.312 (33,325)	1.375 (34,925)	1.625 (41,275)	2.125 (53,975)	2.125 (53,975)
	Hex 2	.750 (19,050)	.875 (22,225)	1.000 (25,400)	1.250 (31,750)	1.375 (34,925)	1.625 (41,275)	2.125 (53,975)	2.125 (53,975)
	F	.550 (13,970)	.556 (14,122)	.657 (16,688)	.758 (19,253)	.864 (21,946)	.911 (23,139)	.958 (24,333)	1.083 (27,508)
	G	1.047 (26,594)	1.125 (28,575)	1.281 (32,537)	1.422 (36,119)	1.593 (40,462)	1.593 (40,462)	1.640 (41,656)	1.656 (42,062)
	H	.453 (11,506)	.469 (11,913)	.562 (14,275)	.625 (15,875)	.688 (17,475)	.688 (17,475)	.688 (17,475)	.688 (17,475)
	I	.969 (24,613)	1.015 (25,781)	1.156 (29,362)	1.297 (32,944)	1.406 (35,712)	1.406 (35,712)	1.406 (35,712)	1.406 (35,712)
	J (Max.)							.465 (11,811)	.238* (6,045)
	K (Max.)							1.880 (47,752)	2.125* (53,975)
	"T" Thread	.4375-20 UNJF-3A	.5625-18 UNJF-3A	.7500-16 UNJF-3A	.8750-14 UNJF-3A	1.0625-12 UNJF-3A	1.3125-12 UNJF-3A	1.6250-12 UNJ-3A	1.8750-12 UNJ-3A

\* with AS4375-24 fitting ends only

# 2000 Series Couplings

## Pressure/Flow Charts

To find the pressure loss (difference between inlet and outlet pressures) for a given coupling size at a given flow rate: 1) find the flow rate at the bottom of the chart and read up until the line intersects the pressure curve for the coupling size in question, 2) read across to find the pressure loss.

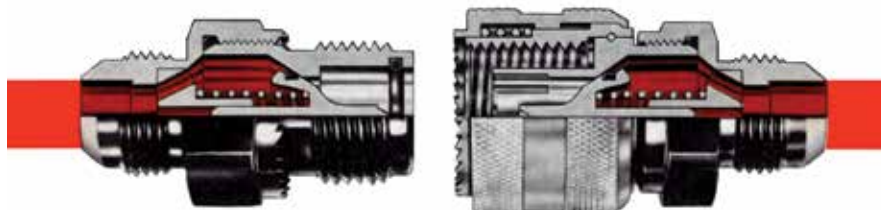
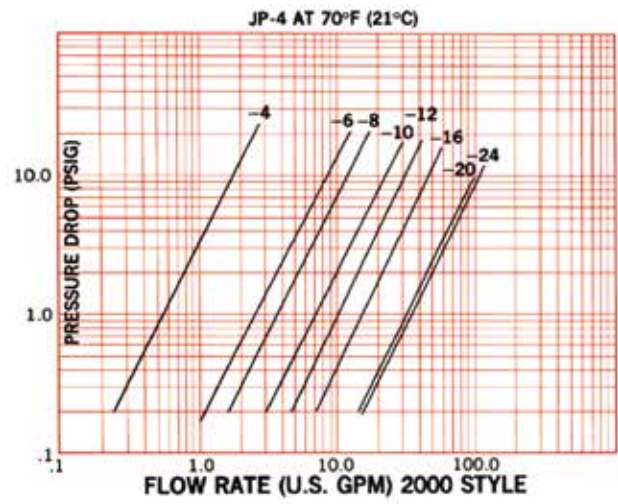
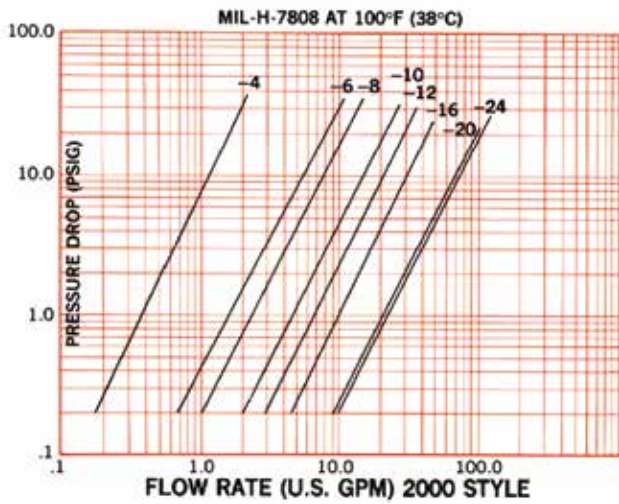

Uncoupled

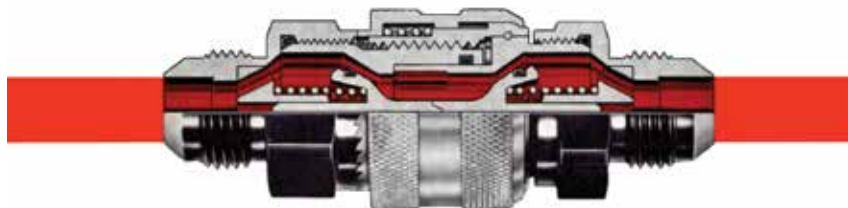

Coupled

**2001 Series Couplings**

Low profile quick disconnect couplings for fuel and oil applications are available with various end fitting combinations. Select the base part number for coupling halves from the table on page 6. Complete the part number by adding the

letter code (for size) to the base number, e.g. AE84027E. Couplings for other fluids and end fitting styles are available. Dust caps and plugs are available for all sizes. Contact Eaton for further information or to order.



**Series 2001 Coupling Assembly**

**Dimensional Data**

See chart on page 6.

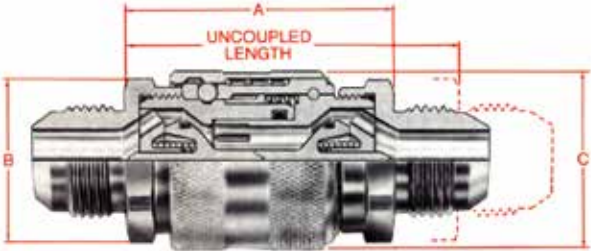

**Coupling Assembly**

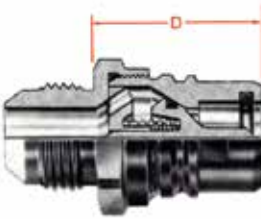

**Coupling Half  
Bulkhead Mounting**



**Coupling Half  
Hose Attaching**

# 2001 Series Couplings

## Styles and Part Numbers

Coupling Half	Style I		Style II		Style III		Style IV	
	AS4395	AS4395	AS4396	AS4395	AS4375	AS4375	AS4377	AS4375
<b>Application</b>	Fuel	Lube Oil	Fuel	Lube Oil	Fuel	Lube Oil	Fuel	Lube Oil
<b>Specification</b>	MIL-C-7413B Type I, Class A	MIL-C-7413B Type II, Class B	MIL-C-7413B Type I, Class A	MIL-C-7413B Type II, Class B	MIL-C-7413B Type I, Class A	MIL-C-7413B Type II, Class B	MIL-C-7413B Type I, Class A	MIL-C-7413B Type II, Class B
<b>Part Number</b>	<b>Coupling Half P/N</b>	AE84022	AE84023	AE84024	AE84025	AE84026	AE84027	AE84028
	<b>Bulkhead Mounting</b>	AE84030	AE84031	AE84030	AE84031	AE84032	AE84033	AE84032
	<b>Coupling Half P/N</b>	AE84022	AE84023	AE84024	AE84025	AE84026	AE84027	AE84028
	<b>Hose Attaching</b>	AE84030	AE84031	AE84030	AE84031	AE84032	AE84033	AE84032

Select the base part number for coupling halves from the table, above. Complete part number by adding the letter code (for size) to the base number (e.g. AE84022E).

To determine overall length, add the end fitting dimension for each end (dimension F, G, H or I from below) to the base assembly length (A or "uncoupled" dimension) for the desired coupling style. For coupling half length, add end fitting dimensions to the basic length (dimension D or E).

## End Fitting Dimensions

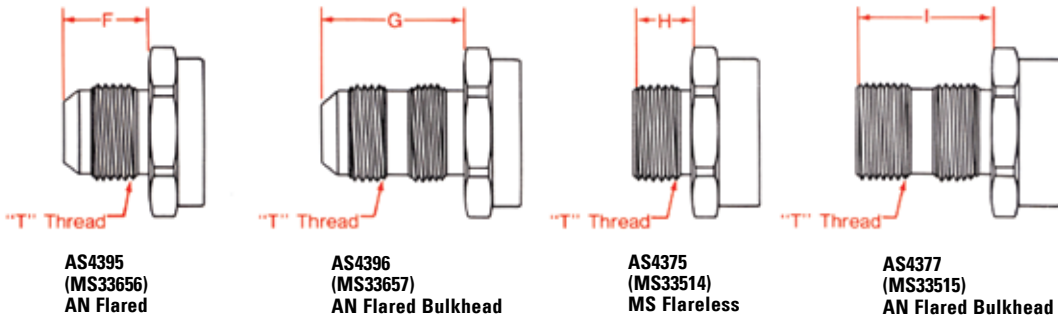

Dimensions shown in inches (mm). Weights shown in pounds (kg).

Letter Code	E	G	H	J	K	M	
<b>Tube Size</b>	<b>1/4</b>	<b>3/8</b>	<b>1/2</b>	<b>5/8</b>	<b>3/4</b>	<b>1</b>	
<b>Dimensions</b>	<b>A</b>	1.626 (41,300)	1.828 (46,431)	1.936 (49,174)	2.300 (58,420)	2.416 (61,366)	2.592 (65,837)
	<b>Uncoupled Length</b>	2.26 (57,40)	2.47 (62,74)	2.66 (67,56)	3.30 (83,82)	3.46 (87,88)	3.73 (94,74)
	<b>B (Max.)</b>	.820 (20,828)	.970 (24,638)	1.105 (28,067)	1.380 (35,052)	1.517 (38,532)	1.825 (46,355)
	<b>C (Max.)</b>	1.000 (25,4)	1.100 (27,94)	1.320 (33,528)	1.575 (40,005)	1.690 (42,926)	2.000 (50,8)
	<b>D (Max.)</b>	.983 (24,968)	1.133 (28,778)	1.163 (29,540)	1.468 (37,287)	1.560 (39,624)	1.689 (42,900)
<b>Weight</b>	<b>Style I</b>	.119 (0,054)	.132 (0,060)	.210 (0,095)	.353 (0,160)	.376 (0,170)	.814 (0,369)
	<b>Style II</b>	.130 (0,059)	.147 (0,066)	.238 (0,108)	.394 (0,178)	.431 (0,195)	.899 (0,408)
	<b>Style III</b>	.123 (0,055)	.136 (0,061)	.216 (0,098)	.356 (0,161)	.375 (0,170)	.817 (0,370)
	<b>Style IV</b>	.128 (0,058)	.144 (0,065)	.231 (0,105)	.378 (0,172)	.413 (0,188)	.866 (0,393)
<b>Dimensions</b>	<b>E (Max.)</b>	1.271 (32,283)	1.334 (33,884)	1.493 (37,922)	1.823 (46,304)	1.895 (48,133)	2.040 (51,816)
	<b>Hex 1</b>	.750 (19,050)	.875 (22,225)	1.000 (25,400)	1.250 (31,750)	1.375 (34,925)	1.625 (41,275)
	<b>Hex 2</b>	.750 (19,050)	.875 (22,225)	1.000 (25,400)	1.250 (31,750)	1.375 (34,925)	1.625 (41,275)
	<b>F</b>	.550 (13,970)	.556 (14,122)	.657 (16,688)	.758 (19,253)	.864 (21,946)	.911 (23,139)
	<b>G</b>	1.047 (26,594)	1.125 (28,575)	1.281 (32,537)	1.422 (36,119)	1.593 (40,462)	1.593 (40,462)
	<b>H</b>	.453 (11,506)	.469 (11,913)	.562 (14,275)	.625 (15,875)	.688 (17,475)	.688 (17,475)
	<b>I</b>	.969 (24,613)	1.015 (25,781)	1.156 (29,362)	1.297 (32,944)	1.406 (35,712)	1.406 (35,712)
	<b>"T" Thread</b>	.4375-20 UNJF-3A	.5625-18 UNJF-3A	.7500-16 UNJF-3A	.8750-14 UNJF-3A	1.0625-12 UNJF-3A	1.3125-12 UNJF-3A

**Pressure/Flow Charts**

To find the pressure loss (difference between inlet and outlet pressures) for a given coupling size at a given flow rate: 1) find the flow rate at the bottom of the chart and read up until the line intersects the pressure curve for the coupling size in question, 2) read across to find the pressure loss.

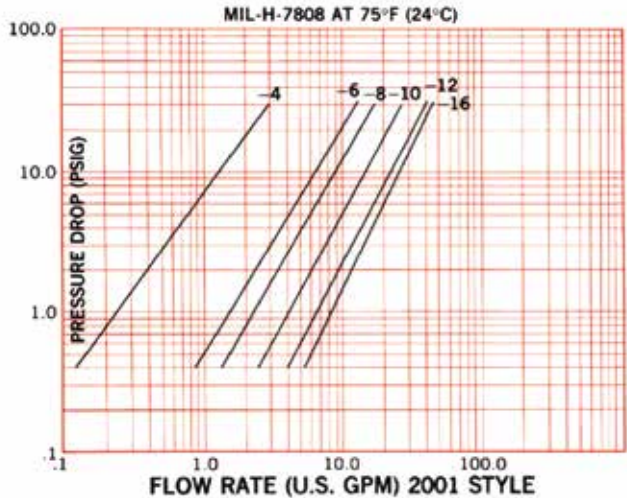
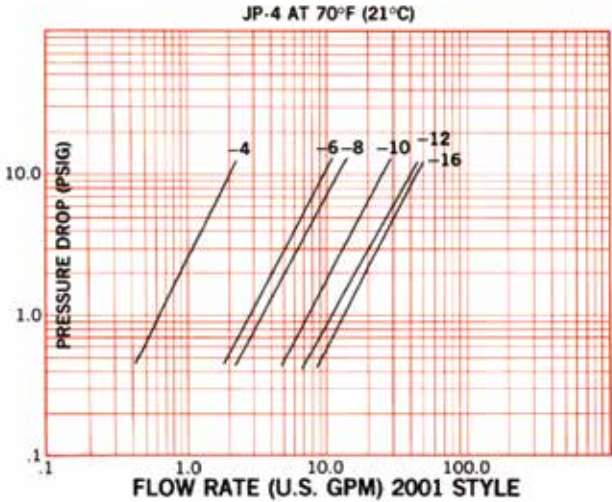

Uncoupled



Coupled

**Eaton**  
**Aerospace Group**  
**Fluid & Electrical Distribution Division**  
**300 South East Avenue**  
**Jackson, Michigan 49203-1972**  
**Phone: (517) 787 8121**  
**Fax: (517) 789 2947**



Eaton  
Aerospace Group  
9650 Jeronimo Road  
Irvine, California 92618  
Phone: (949) 452 9500  
Fax: (949) 452 9555  
[www.eaton.com/aerospace](http://www.eaton.com/aerospace)

Copyright © 2013 Eaton  
All Rights Reserved  
Form No. TF100-59C  
(Supersedes AEB238A)  
December 2015